

# 291-8K/291-16K COMPRESSION DRIVER LOUDSPEAKER



Patent No. D239,537

## DESCRIPTION

The Altec 291-8K and 291-16K Compression Driver loudspeaker has been designed for use in high-level sound systems of the highest quality. It may be used with Altec Mantaray, multicellular or sectoral horns and will provide a smooth response from 500-13,000 Hz. This wide range, when used in conjunction with Altec low-frequency loudspeakers, will provide full high-fidelity reproduction for the largest theatre or auditorium. Improvements in diaphragm/voice coil assemblies and magnetic structures allow the 291-8K and 291-16K to exact a smoother and extended response characteristic over the 500-13,000 Hz band. The 291-16K has a minimum impedance of 16 ohms; the 291-8K, 8 ohms.

The diaphragm/voice coil assembly of the 291-8K and 291-16K can be replaced in the field by untrained personnel without the use of special tools. Adjustable dowel pins allow each voice coil to be precisely centered in the voice coil gap, which has a flux density of 2.05 T derived from a 6.87-pound Ferrite V magnet.

These improvements combine to produce a high-frequency compression driver loudspeaker of virtually matchless quality and limitless application.

## SPECIFICATIONS

<b>Power Capacity:</b>	50 watts average pink noise (Above measurement made on Altec 300 or 50 Hz horn, with signal band-limited from 500-20,000 Hz)
<b>Frequency Response:</b>	500-13,000 Hz
<b>Pressure Sensitivity:</b>	109 dB-SPL (re: 20 $\mu$ Pa) with 1 W of pink noise band-limited 500 Hz-16 kHz, at 1 M from lips of MRL1594A horn.
<b>Minimum Impedance:</b>	291-8K—8 ohms 291-16K—16 ohms
<b>Construction — Magnet:</b>	6.87-pound Ferrite V, 2.05 T flux density
<b>Magnetic Structure Weight:</b>	29.5 pounds
<b>Diaphragm:</b>	Aluminum dome with Kapton <sup>®</sup> suspension
<b>Voice Coil:</b>	2.8" diameter of edge-wound aluminum ribbon
<b>Dimensions:</b>	7.61" (19.32 cm) diameter 5.8" (14.8 cm) depth, less mounting studs
<b>Weight:</b>	30.5 pounds (13.83 kg)
<b>Finish:</b>	Gray "Hammer-tone" textured enamel
<b>Mounting Data:</b>	User adjustable for Altec standard 3-bolt flange or 4-bolt flange.

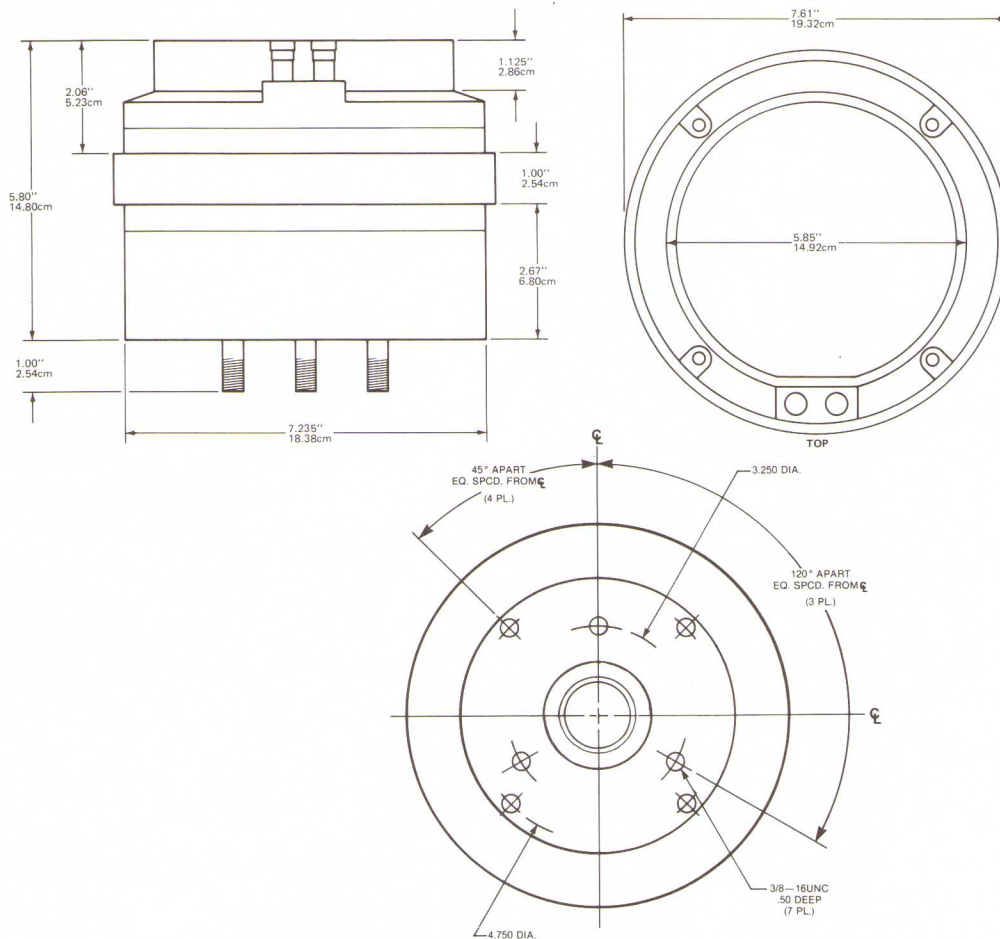

ROW 1 (1 : 3)



ROW 2 (4 : 4)



### ARCHITECT'S AND ENGINEER'S SPECIFICATIONS

The compression driver loudspeaker shall meet the following criteria. Power capacity: 50 watts average pink noise, band-limited from 500-20,000 Hz and measured with Altec 300 or 500 Hz horn. Frequency response, uniform from 500 to 13,000 Hz. Pressure sensitivity shall be 109 dB-SPL (re: 20  $\mu$ Pa), with 1 W of pink noise band-limited 500 Hz-16 kHz, at 1 M from lips of MR11594A horn. Minimum impedance: 8 ohms (291-8K), 16 ohms (291-16K). The voice coil shall be 2.8" in diameter, of edge-wound aluminum ribbon, and shall operate in a magnetic gap having a flux density of 2.05 T derived from a 6.87-pound Ferrite V magnet. The diaphragm shall be an aluminum dome and shall have Kapton<sup>®</sup> suspension. A Tangerine<sup>®</sup> phasing plug

with 13 radial acoustic slots shall serve as the pole piece and shall also be utilized to provide the proper phase relationship between the sound emanating from the center and edges of the diaphragm and voice coil assembly. The entire diaphragm and voice coil assembly shall be field replaceable without requiring special tools or skills; adjustable dowel pins shall allow each voice coil to be precisely centered in the voice coil gap. The drive shall be 7.61" in diameter by 5.8" deep (excluding 1" depth of mounting studs), and shall weigh 30.5 pounds.

The compression driver loudspeaker shall be the Altec Model 291-8K or 291-16K.



P.O. BOX 26105, OKLAHOMA CITY, OKLAHOMA 73126-0105, U.S.A.

© 1986 ALTEC LANSING CORPORATION